

## Pressure / Force Table

		AREA RATIO			THEORTICAL FORCES							
					PUSHING FORCE ON PISTON AREA				PULLING FORCE ON ANNULUS AREA			
PISTON DIA	ROD DIA	PISTON AREA	ROD AREA	ANNULUS AREA	100 bar	150 bar	200 bar	250 bar	100 bar	150 bar	200 bar	250 bar
mm	mm	mm <sup>2</sup>	mm <sup>2</sup>	mm <sup>2</sup>	ton	ton	ton	ton	ton	ton	ton	ton
40	25	1260	490	770	1.26	1.89	2.52	3.15	0.77	1.16	1.54	1.93
50	25	1960	490	1470	1.96	2.94	3.93	4.91	1.47	2.21	2.94	3.68
	30		710	1250	1.96	2.94	3.93	4.91	1.25	1.87	2.5	3.13
63	30	3120	710	2410	3.12	4.68	6.24	7.8	2.41	3.62	4.82	6.02
	35		960	2160	3.12	4.68	6.24	7.8	2.16	3.24	4.32	5.4
	40		1260	1860	3.12	4.68	6.24	7.8	1.86	2.79	3.72	4.65
80	40	5020	1260	3770	5.02	7.53	10	12.6	3.77	5.66	7.54	9.43
	45		1590	3430	5.02	7.53	10	12.6	3.43	5.15	6.86	8.58
	50		1960	3060	5.02	7.53	10	12.6	3.06	4.59	6.12	7.65
90	45	6360	1590	4770	6.36	9.54	12.7	15.9	4.77	7.16	9.54	11.9
	50		1960	4400	6.36	9.54	12.7	15.9	4.4	6.6	8.8	11
	60		2830	3530	6.36	9.54	12.7	15.9	3.53	5.3	7.06	8.83
100	50	7850	1960	5890	7.85	11.8	15.7	19.6	5.89	8.84	11.8	14.7
	70		3850	4000	7.85	11.8	15.7	19.6	4	6	8	10
120	60	11310	2830	8480	11.3	17	22.7	28.3	8.5	12.7	17	21.2
	70		3850	7460	11.3	17	22.7	28.3	7.5	11.2	15	18.7
125	60	12270	2830	9440	12.3	18.4	24.5	30.7	9.44	14.1	18.9	23.6
	65		3320	8950	12.3	18.4	24.5	30.7	8.95	13.4	17.9	22.4
	70		3850	8420	12.3	18.4	24.5	30.7	8.42	12.6	16.8	21.2
140	70	15390	3850	11540	15.4	23.1	30.8	38.5	11.54	17.31	23.1	28.9
	90		6360	9030	15.4	23.1	30.8	38.5	9.03	13.55	18.06	22.6
150	80	17670	5030	12640	17.7	26.5	35.3	44.18	12.64	18.96	25.28	31.6
	90		6360	11310	17.7	26.5	35.3	44.18	11.31	16.97	22.62	28.28
160	90	20110	6362	13748	20.1	30.2	40.2	50.3	13.7	20.6	27.5	34.4
	100		7850	12260	20.1	30.2	40.2	50.3	12.3	18.4	24.5	30.7
180	90	25450	6360	19090	25.5	38.2	50.9	63.6	19.1	28.6	38.2	47.7
	100		7854	17596	25.5	38.2	50.9	63.6	17.6	26.4	35.2	44
	125		12270	13180	25.5	38.2	50.9	63.6	13.2	19.8	26.4	33
200	100	31420	7850	23570	31.4	47.1	62.8	78.8	23.6	35.4	47.1	58.9
	125		12270	19150	31.4	47.1	62.8	78.8	19.2	26.4	35.2	44
	140		15400	16020	31.4	47.1	62.8	78.8	16	24	32	40.1
230	125	41540	12270	29270	41.5	62.3	83.1	103.8	29.2	43.9	58.5	73.2
	140		15400	26140	41.5	62.3	83.1	103.8	26.1	39.2	52.3	65.4
250	125	49090	12270	36730	49.1	73.6	98.2	123	36.7	55.1	73.5	91.8
	140		15400	33690	49.1	73.6	98.2	123	33.7	50.5	67.4	84.2
	180		25450	23640	49.1	73.6	98.2	123	23.6	35.5	47.3	59.1

## Pressure -Thrust- Consumption Table For Welded Cylinder

Cylinder Bore mm	Piston Area mm <sup>2</sup>	Out-Stroke Thrust in KiloNewtons Pressure of Operating Medium (bar)					Consumption per 0.01metres of stroke in one direction
		10	40	100	160	210	Oil Liters Dispalaced
40	1256.6	1.2566	5.0264	12.566	20.1056	26.3886	0.012566
50	1963.5	1.9635	7.854	19.635	31.416	41.2335	0.019635
63	3117.3	3.1173	12.4692	31.173	49.8768	65.4633	0.031173
80	5026.5	5.0265	20.106	50.265	80.424	105.5565	0.050265
90	6361.7	6.3617	25.4468	63.617	101.7872	133.5957	0.063617
100	7853.9	7.8539	31.4156	78.539	125.6624	164.9319	0.078539
120	11309.7	11.3097	45.2388	113.097	180.9552	237.5037	0.113097
125	12271.8	12.2718	49.0872	122.718	196.3488	257.7078	0.122718
140	15393.8	15.3938	61.5752	153.938	246.3008	323.2698	0.153938
150	17671.5	17.6715	70.686	176.715	282.744	371.1015	0.176715
160	20106.2	20.1062	80.4248	201.062	321.6992	422.2302	0.201062
180	25446.9	25.4469	101.7876	254.469	407.1504	534.3849	0.254469
200	31415.9	31.4159	125.6636	314.159	502.6544	659.7339	0.314159
250	49087.4	49.0874	196.3496	490.874	785.3984	1030.8354	0.490874

## Deduct The Following Force Corresponding To Rod Size From Out-Stroke Thrusts To Determine In-Stroke Pull

Rod Diameter mm	Rod Area cm <sup>2</sup>	Out-Stroke Thrust in KiloNewtons Pressure of Operating Medium (bar)					Consumption per 0.01metres of stroke in one direction
		10	40	100	160	210	Oil Liters Dispalaced
25	490.9	0.4909	1.9636	4.909	7.8544	10.3089	0.004909
30	706.9	0.7069	2.8276	7.069	11.3104	14.8449	0.007069
35	962.1	0.9621	3.8484	9.621	15.3936	20.2041	0.009621
40	1256.6	1.2566	5.0264	12.566	20.1056	26.3886	0.012566
45	1590.43	1.59043	6.36172	15.9043	25.44688	33.39903	0.0159043
50	1963.5	1.9635	7.854	19.635	31.416	41.2335	0.019635
60	2827.4	2.8274	11.3096	28.274	45.2384	59.3754	0.028274
65	3318.3	3.3183	13.2732	33.183	53.0928	69.6843	0.033183
70	3848.5	3.8485	15.394	38.485	61.576	80.8185	0.038485
80	5026.5	5.0265	20.106	50.265	80.424	105.5565	0.050265
90	6361.7	6.3617	25.4468	63.617	101.7872	133.5957	0.063617
100	7853.9	7.8539	31.4156	78.539	125.6624	164.9319	0.078539
110	9503.3	9.5033	38.0132	95.033	152.0528	199.5693	0.095033
125	12271.8	12.2718	49.0872	122.718	196.3488	257.7078	0.122718
140	15393.8	15.3938	61.5752	153.938	246.3008	323.2698	0.153938
180	25446.9	25.4469	101.7876	254.469	407.1504	534.3849	0.254469

## Rod Size And Stop Tube Selection

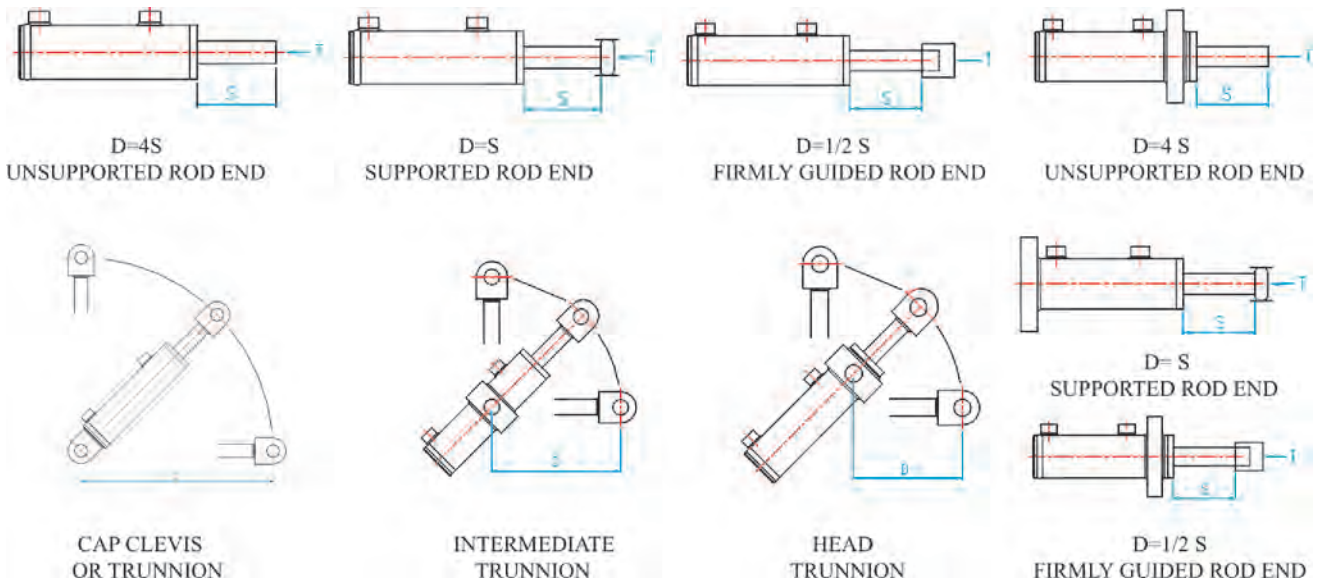

### Rod Size Selection :

Standard rod sizes are normally suitable for all application except for long stroke or high thrust application. Proper selection of minimum rod size may be determine by the following steps:

1. With knowledge of bore and stroke, thrust may be determine. Refer to Graph 1.
2. Select from illustration above, the type of mounting to be used and determine the length of "D" with the piston rod in the fully extended position.
3. Find the value of "D" at the bottom of the graph and follow its line vertically until it intercepts the horizontal line representing the maximum push thrust that will be applied to your cylinder. The intersection of these two lines will fall within a stripe representing the minimum recommended piston rod diameter for your application.

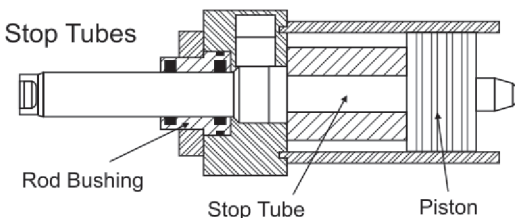

Stop tubes are located between the piston and the rod shoulder on the head end of the cylinder. Bearing loading is reduced by separating the piston and the rod bushing. Bearing wear and tendency to buckle is reduced.

To determine if a stop tube is required and the length of stop tube needed, use the following procedure:

Determine the value of "D" with the piston rod in the fully extended position. If the value of "D" is under 1000mm, no stop tube is needed. If "D" is greater than 1000mm, 25mm stop tube is recommended for each 250mm or fraction thereof beyond 1000mm.

### Column Strength

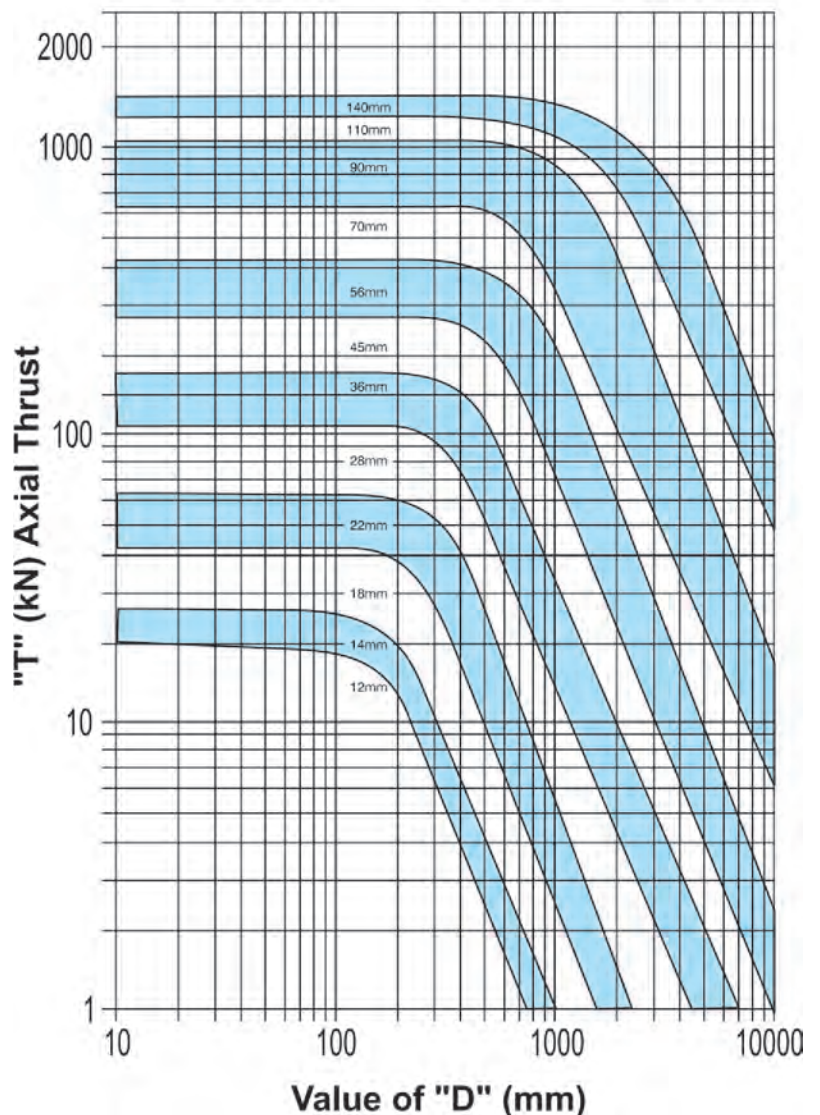

## Calculation Of Force Output And Maximum Permissible Buckle Load

### Permissible buckle load

$$F_{kt} = \frac{\pi^2 \cdot E \cdot I}{n \cdot L_f^2} *$$

- $F_{kt}$  = Permissible buckle load (N)
- $E$  = Elasticity module (210000N/mm<sup>2</sup>)
- $I$  = Moment of inertia (mm<sup>4</sup>)
- $n$  = Safety factor

\* applies when  $89 \leq \lambda \leq 200$

$$\lambda = \frac{4 L_f}{d}$$

### Cylinder's force output

$$F = \frac{\pi \cdot D^2 \cdot P}{4}$$

- $F$  = Cylinder's force output (N)
- $D$  = Cylinder bore diameter (mm)
- $P$  = Cylinder pressure (Mpa)

(1 Mpa = 10 bar)

